

6-Axis F/T Sensor

HEX-70-XE-200N

Description:

OptoForce 6 axis F/T sensors provide 6 degrees of freedom force and torque measurement. Our sensors are designed to fit most of the currently used industrial robot arms. Integration with the various available interfaces is simple. Common applications are **force control** devices, **teach in activities**, and **crash detection**, but the sensors can be used next to **end effectors** in case of **grinding**, **polishing** or **deburring** tools. High durability and an unlimited number of custom opportunities resemble all of our sensor types.

We offer these sensors mostly for **system integrator** companies, **robot arm manufacturers** and **contract manufacturing** companies.

Benefits:

- Multi axis force measurement
- High resolution
- Highly adaptable product design
- Dust and water proof (IP65)
- High overload range
- Mechanical shock resistant
- Cost efficient solution
- Easy integration

	Nominal Capacity	Deformation (Deflection)
Fxy	± 200 N	± 1.7 mm
Fz	± 200 N	± 0.3 mm
Txy	± 10 Nm	(± 2 °)
Tz	± 6.5 Nm	(± 5 °)



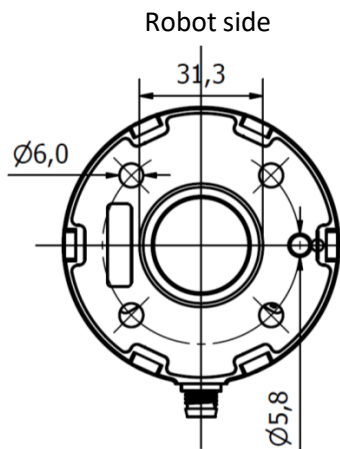
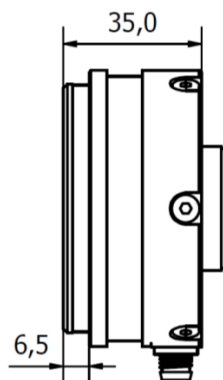
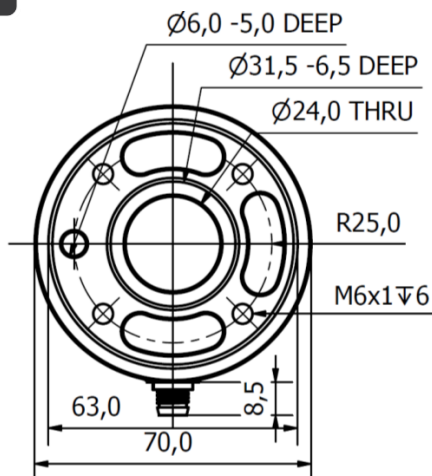

Connector pinout

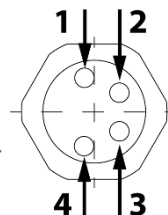

- 1 : V+
2 : CAN High
3 : CAN Low
4 : V-

Compatible with coupling ISO 9409-1-50-4-M6

SPECIFICATIONS

Sensor Type	6 Axis Force Sensor			
Dimensions	Height x diameter		35 x 70 mm	
Weight	(With built-in adapter plates)		200g	
	Fz	Fxy	Txy	Tz
Nominal Capacity (N.C)	200 N	200 N	10 Nm	6.5 Nm
Single axis overload	200 %	200 %	200 %	200 %
Full scale nonlinearity	2 %	2 %	2 %	2 %
Resolution (typical)	133.33 mN	± 22.22 mN	± 1 mNm	± 0.65 mNm
Single axis deformation at N.C	± 0.3 mm	± 1.7 mm	± 2.5 °	± 5 °
Crosstalk (typical)	< 5 %			
Hysteresis (measured on Fz axis , typical)	< 2 %			
Working temperature range	-40 °C - +80 °C			
Temperature compensation	All axes		-10 °C - +40 °C	
Power requirement	DC input range 7-48V		0.8 W	
Robot mounting screw	4 x M6 x 8 mm		DIN7984-A20-0130	
Sensor mounting screw	6 x M4 x 8 mm		DIN7984-A20-050	

INTERFACE TYPES

USB	CAN	Ethernet - TCP/UDP	EtherCAT
Maximum sampling frequency 1000 Hz			
Supported systems Windows; Linux; ROS; UR			

